

Part # 3132 FXR Fat Tire Kit (160 Series Tire)

vulcanworks.net
603-668-6315

- (1) This kit uses the O.E.M. caliper
- (2) Our caliper bracket is offset .300 which centers the tire in the frame
- (3) Install 5/16 thick pulley spacer
- (4) Install left side axle spacer, replace O.E.M. spacer (41591-81) with the provided spacer
- (5) Grind fender strut boss (4 holes) flush to frame so a wider fender can be installed
- (6) Install fender struts with fender strut spacers.

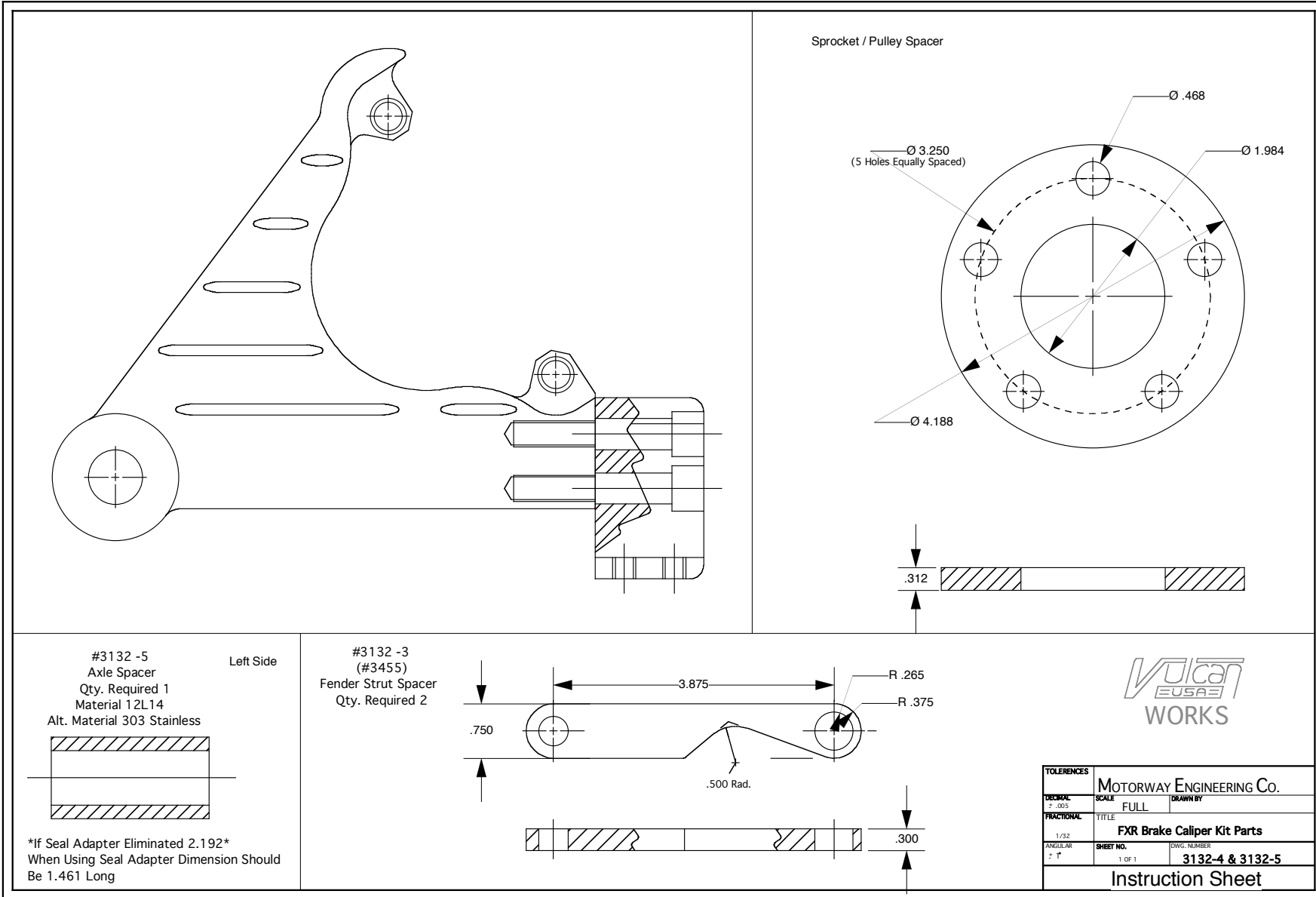

If Seal Adapter Eliminated 2.192
When Using Seal Adapter Dimension Should
Be 1.461 Long